

# Project Fiber



hempitecture®

Presented by:  
Mattie Mead: CEO + Founder





# Today's Talk:

The who, what, where, when, and why  
of "Project Fiber"



SOUTHERN  
IDAHO ECONOMIC  
DEVELOPMENT



hempitecture®

## Our Team



**Matthew Mead**  
Founder & CEO



**Tommy Gibbons**  
Cofounder & COO



**Aimee Christensen**  
Strategic Advisor



**Dr. Brian George**  
Strategic Advisor



# What we do:

We are the leading provider of **sustainable, hemp based building materials** in North America.

# Why we do it:

Our **two flagship products** embody CO2 and make healthier, more energy efficient habitats.





**Simply put:**

Hempitecture specializes in the most sustainable building materials **on the planet.**

We're a for-profit Public Benefit Corporation.



An aerial photograph of a suburban neighborhood. The scene shows a grid of streets with houses, green lawns, and trees. In the foreground, a street intersection is visible with a crosswalk. A house with a swimming pool and a trampoline is prominent in the lower right. The overall atmosphere is bright and clear.

# Problem

Our built environment has **toxic materials**.

Buildings consume **40%** of our **energy**.

Buildings are responsible for 40% of our **carbon footprint**.



# Carbon Impacts

CO<sub>2</sub> per 4'x8' wall panel at R-28

1040.60 lb CO<sub>2</sub> emitted

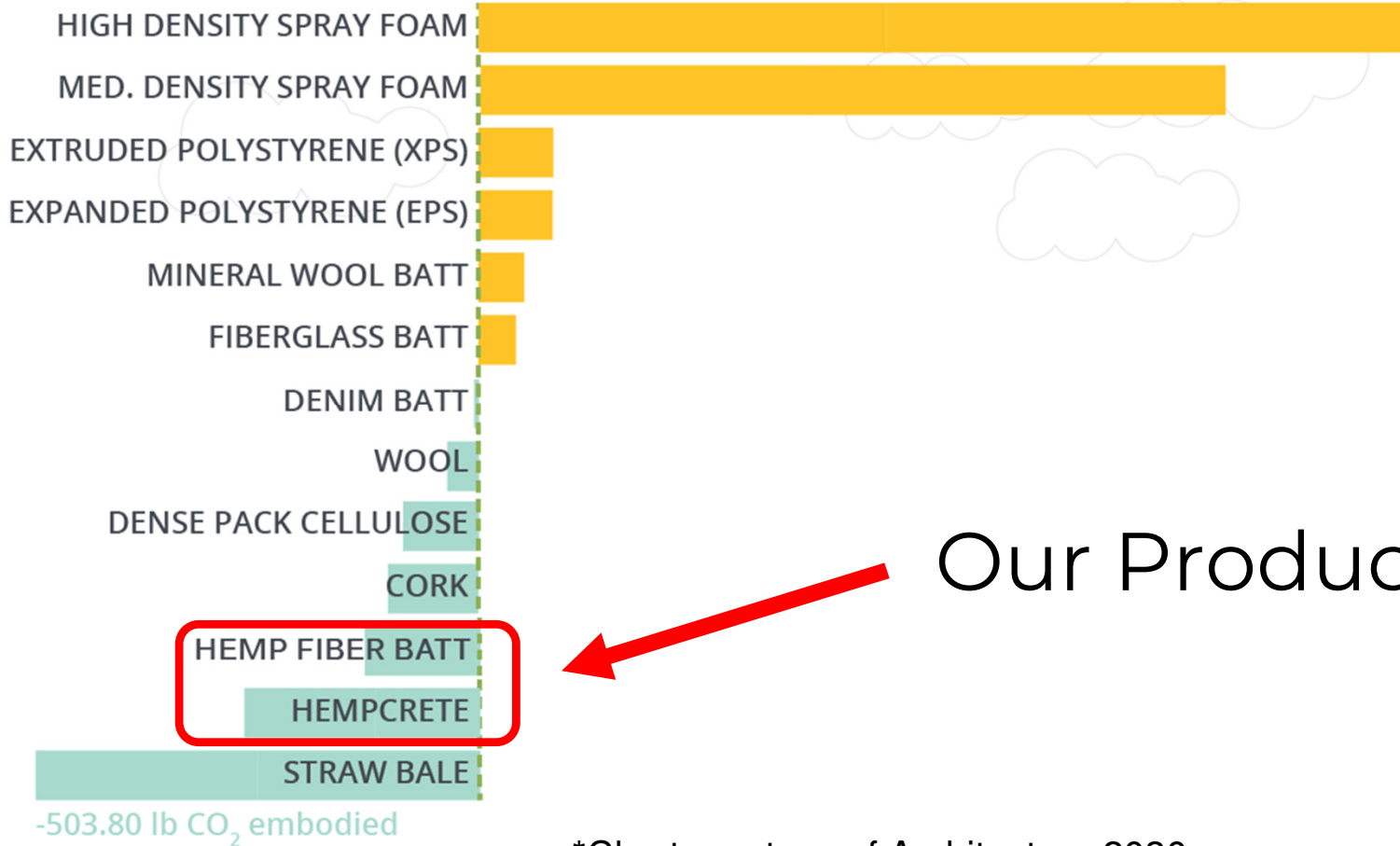

Our Products

\*Chart courtesy of Architecture 2030



# Solution

**Healthy**, plant based insulation that absorbs **carbon dioxide**, and makes homes more **energy efficient**.

Our material feedstock offsets

**9.8 tons of CO2 / acre**

**Healthier** home, **happier** people,  
more **sustainable planet**.



# Why Hemp?

**Biomass** from rapidly-renewable Industrial Hemp is our key ingredient.

Industrial hemp is legal in 50 states.

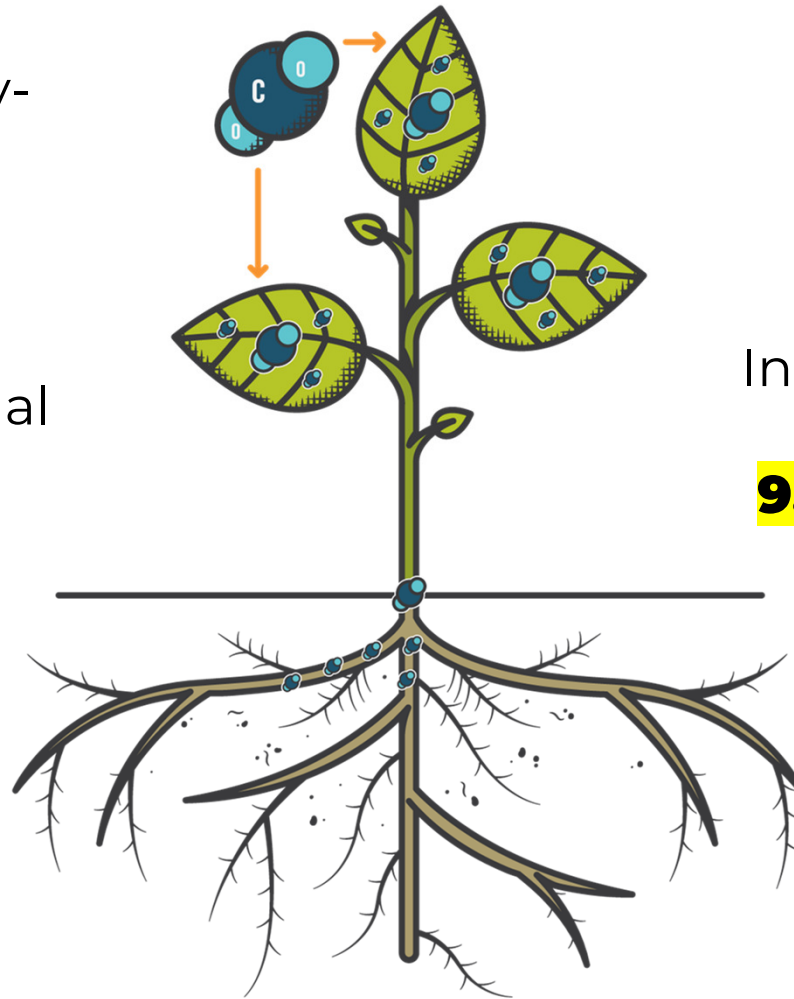

Industrial Hemp offsets:

**9.8 tons of CO<sub>2</sub> / acre**



# HempWool<sup>®</sup>

Our newest product offering: **Natural Fiber Insulation**

1-to-1 replacement for traditional  
Insulation. We own the trademark.

250 HempWool customers & growing

**Now:** Importing from manufacturing partner

**With funding:** Manufacture in Southern Idaho



**HempWool Pilot Testing: 5/3/21**



# Manufacturing technology meets agricultural

**fiber:**

**Phase 1:** *Underway.* Build market, grow customer base, generate revenue.

**Phase 2:** *Q3 2022. USA Manufacturing Facility.* Southern ID location TBD, supply chain secured, offer on equipment pending funding.

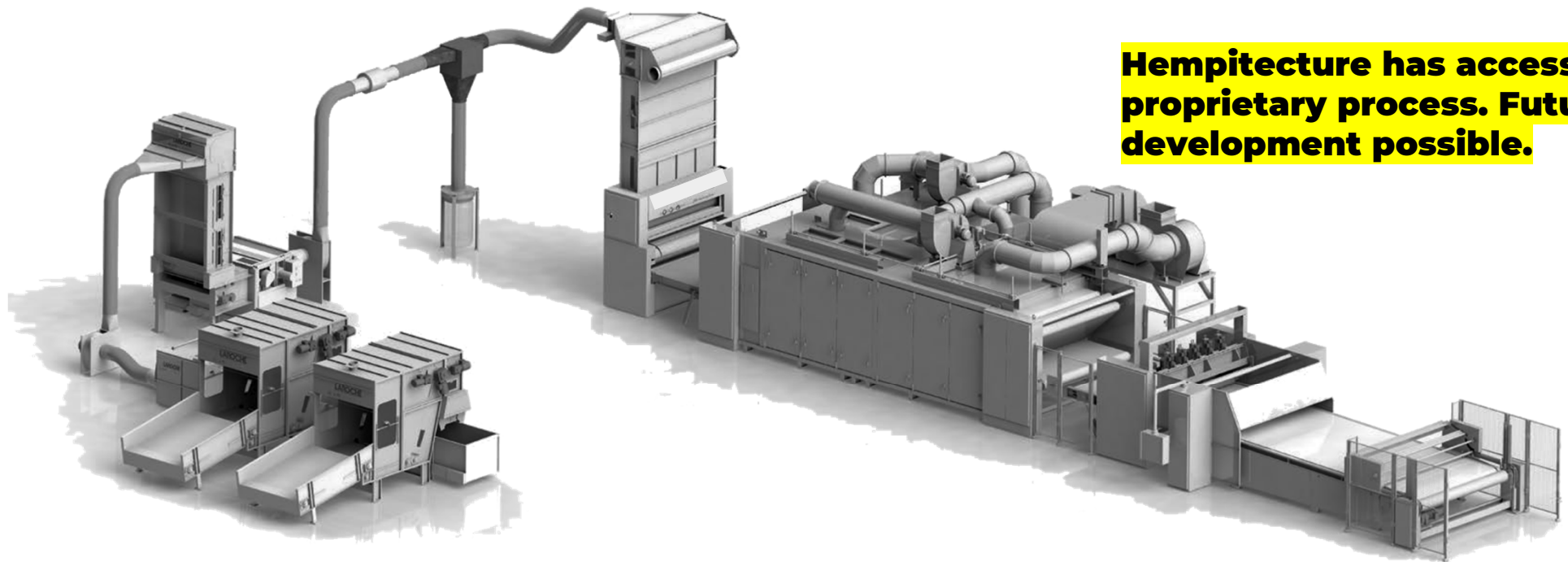

**Hempitecture has access to proprietary process. Future IP development possible.**





# Funding Strategy



Crowd SAFE raise June 1st, 2021

\$2.5mm with \$25mm valuation cap with 20% discount

We're using Reg CF Crowdfunding to build a community of loyal brand ambassadors, who share in the upside of our growth.



\$2.5mm via SBA 504 program - currently ongoing.





# Why Southern Idaho?





# Thank you.



**hempitecture®**

*a Public Benefit Corporation*

Mattie Mead - Founder & CEO

[mattie@hempitecture.com](mailto:mattie@hempitecture.com)

973-727-7902

Tommy Gibbons - Founder &  
COO

[tommy@hempitecture.com](mailto:tommy@hempitecture.com)

973-943-9239

